



**W83772G**  
**Winbond**  
**H/W Monitoring IC**

Date: 05/22/2006    Revision: 1.0



### W83772G Data Sheet Revision History

	PAGES	DATES	VERSION	VERSION ON WEB	MAIN CONTENTS
1	n.a.	07/26/05	0.1	NA	For Winbond internal use only
2		08/10/05	0.2		For Winbond internal use only
3		08/25/05	0.31		For Winbond internal use only
4		10/31/05	0.32		<ol style="list-style-type: none"> <li>1. Change part number from W83L772G to W83772G.</li> <li>2. Modify the top marking</li> </ol>
5		03/01/06	0.5		Preliminary datasheet.
6		05/22/06	1.0		<ol style="list-style-type: none"> <li>1. Update Chap 3.</li> <li>2. Update Chap 7.6 and Chap 7.7 description.</li> <li>3. Add Chap 7.3</li> <li>4. Add Chap 8: PCB Layout Guide</li> <li>5. Update Chap 9</li> <li>6. Update Chap 10.2: DC Characteristic Table for SST, ADDx and D+ pin</li> <li>7. Add Chap 11: Order Information</li> </ol>



## **Table of Content-**

1.	GENERAL DESCRIPTION .....	1
2.	FEATURES .....	1
2.1	Monitoring Items - Temperature .....	1
2.2	General .....	1
2.3	Package .....	1
3.	KEY SPECIFICATIONS .....	2
4.	BLOCK DIAGRAM .....	2
5.	PIN CONFIGURATION .....	3
6.	PIN DESCRIPTION.....	3
7.	FUNCTIONAL DESCRIPTION.....	4
7.1	General Description.....	4
7.2	Access Interface .....	4
7.3	Power-On Reset.....	4
7.4	Measured Temperature Data Format.....	5
7.5	Sensor Error Conditions.....	5
7.6	Conversion Time .....	5
7.7	Address Selection .....	5
8.	PCB LAYOUT GUIDE .....	7
9.	COMMAND SUMMARY .....	8
10.	ELECTRICAL CHARACTERISTIC .....	9
10.1	Absolute Maximum Ratings .....	9
10.2	DC Characteristics .....	9
10.3	AC Characteristics.....	10
11.	ORDER INSTRUCTION.....	11
12.	TOP MARKING .....	11
13.	PACKAGE SPECIFICATION .....	12



## 1. GENERAL DESCRIPTION

W83772G is a 2-channel temperature sensor with Simple Serial Transport (SST) interface. W83772G has an on-chip thermal sensor and a remote temperature sensor. The remote temperature sensor input could be connected to thermal diode or transistor such as 2N3904. A 10-bit ADC (Analog-to-Digital Converter) is built inside W83772G to convert the monitored temperature value with 0.125°C resolution.

W83772G is a high precision, low-power consumption IC supporting 1.5V SST interface. The package type is 8-pin, TSSOP, and the operating voltage is 3.3 V  $\pm$ 10%.

## 2. FEATURES

### 2.1 Monitoring Items - Temperature

- Measure temperature with high accuracy
- One on-chip thermal sensor
- One remote temperature sensor

### 2.2 General

- 3.3V $\pm$ 10% VCC operation
- 16-bit two's complement data format, 0.125°C resolution
- Two address selection pins
- Support Simple Serial Transport interface

### 2.3 Package

- 8-pin TSSOP



### 3. KEY SPECIFICATIONS

- On-die temperature range and accuracy  
0°C to 70°C  
± 3°C (over entire range)  
± 1°C (40°C to 70°C)
- Remote temperature range and accuracy  
-30°C to +127.875°C  
± 3°C (over entire range)  
± 1°C (40°C to 90°C)
- Supply voltage  
3.3V ±10%
- Operating supply current  
5.6 mA typ.
- ADC resolution  
10 Bits
- Operating Temperature Range  
0°C to 70°C

### 4. BLOCK DIAGRAM

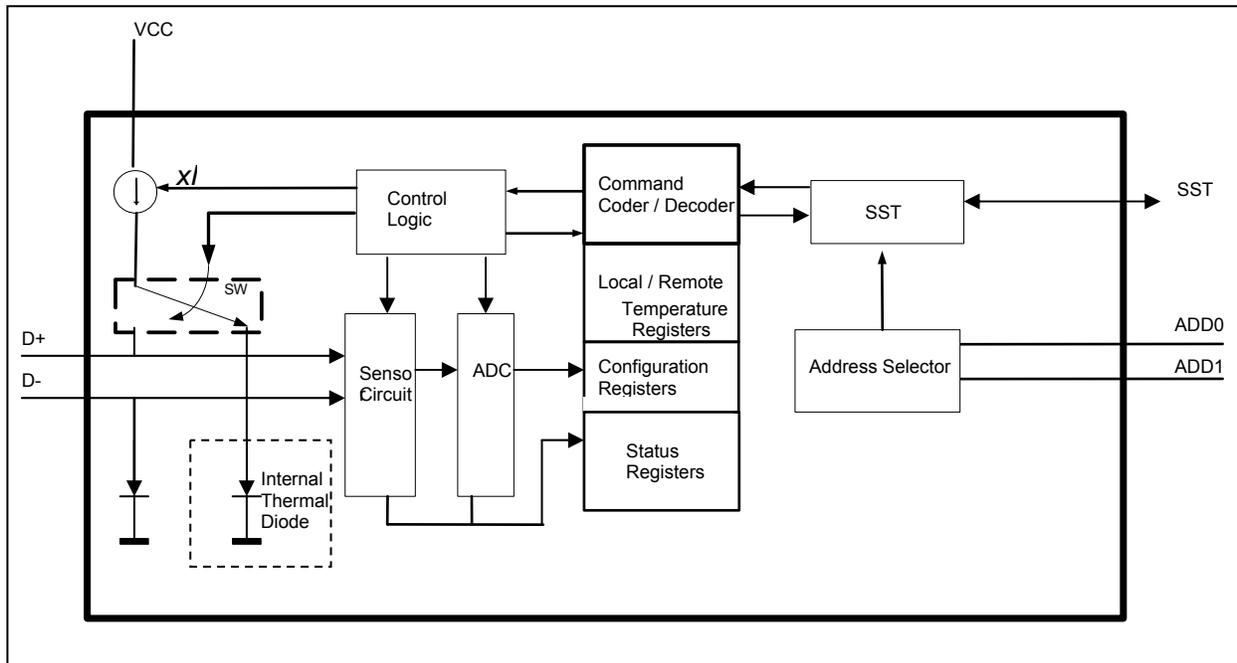



## 5. PIN CONFIGURATION

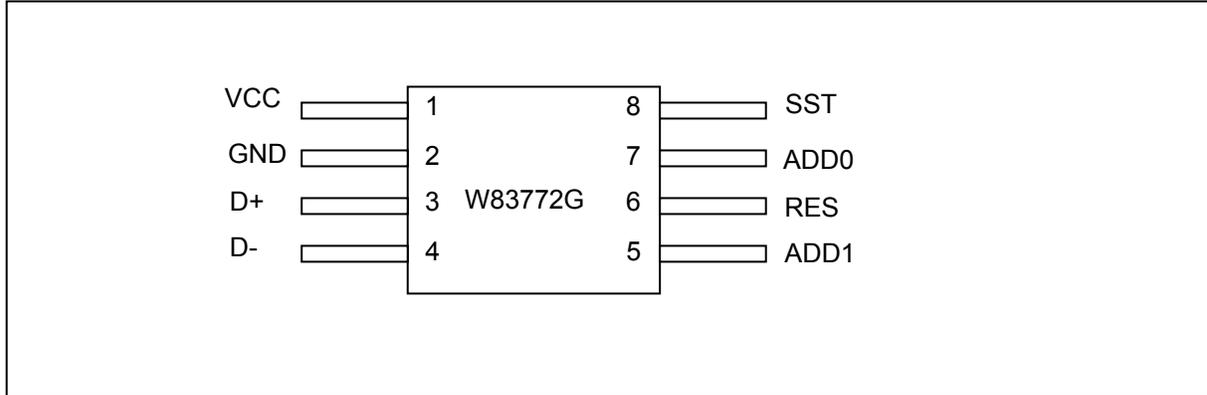

## 6. PIN DESCRIPTION

PIN NAME	NO	PIN TYPE	DESCRIPTION
VCC	1	POWER	DC Power Supply Voltage Input 3.3V±10%.
GND	2	GROUND	Power Supply Ground
D+	3	AIN	Connect to Thermal Diode Anode
D-	4	AIN	Connect to Thermal Diode Cathode
ADD1	5	IO	For Address select
RES	6		Reserved
ADD0	7	IO	For Address select
SST	8	IO	Simple Serial Transport (SST) Interface



## 7. FUNCTIONAL DESCRIPTION

### 7.1 General Description

The W83772G provides one remote temperature sensor input which could be connected to 2N3904 transistors, or CPU/GPU thermal diode, and one local on-die thermal sensor to detect ambient temperature.

The data format of monitored temperature is 16-bit 2's complement with 1-wire SST access interface.

### 7.2 Access Interface

The W83772G provides SST interface to read/write internal registers, and the SST address is xxxxxxxb, respectively. Please refer to 7.7 Address Selection.

### 7.3 Power-On Reset

The power-on reset threshold is 2.7V (typical). When Vcc crosses this threshold, the internal reset signal will be asserted for 4mS. During this time period, W83772G is in the reset state. When the internal reset signal is de-asserted, W83772G is in the operating state.

In the operating state, if Vcc drops below 2.4V and then rises above 2.7, the internal reset signal will be asserted immediately. Fig 1 illustrates the reset mechanism.

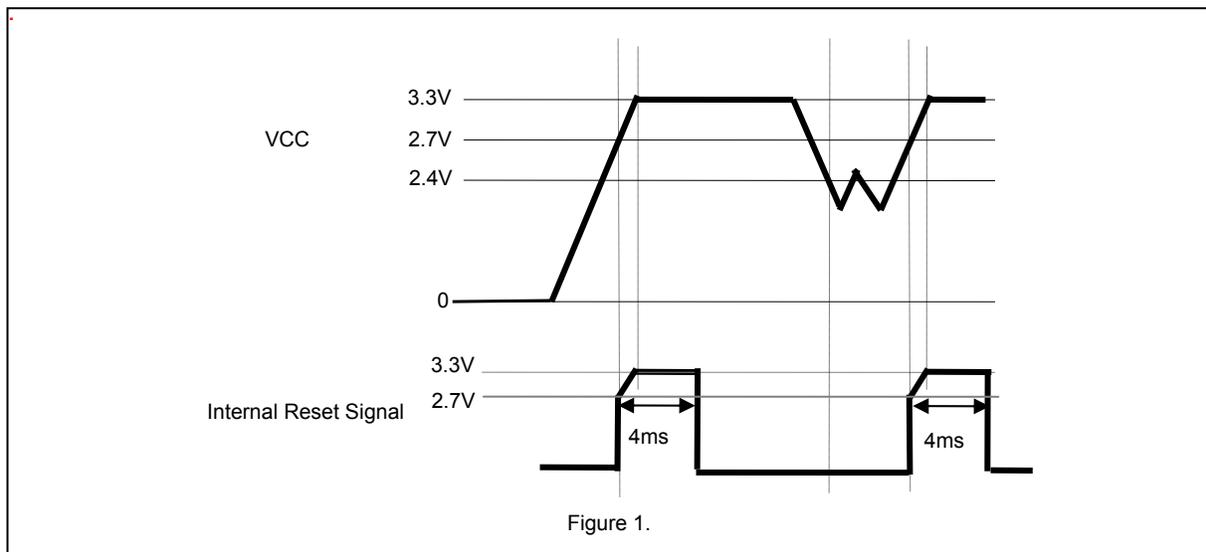



#### 7.4 Measured Temperature Data Format

The W83772G temperature data format of both remote and local temperature are 16-bit two's complement format.

Table 1 shows temperature data with 16-bit two's complement data format.

TEMPERATURE	16-BIT DIGITAL OUTPUT
+80°C	0001 0100 0000 0000
+79.875°C	0001 0011 1111 1000
+1°C	0000 0000 0100 0000
+0°C	0000 0000 0000 0000
-1°C	1111 1111 1100 0000
- 5°C	1111 1110 1100 0000

Table 1. Temperature Data Format

#### 7.5 Sensor Error Conditions

When the external diode is opened or shorted, the W83772G will return 0x8001 in response to either the SST command GetExtTemp() or GetAllTemp() command. It will also return 0x8002/0x8003 when detecting temperature below -128°C /above +128°C.

#### 7.6 Conversion Time

W83772G provide 250mS conversion time for monitoring all temperature readings. The conversion time is related to the internal self-generated clock. The internal clock frequency is dependent on the temperature. There is 10% frequency deviation in the operating temperature range of 0°C and 70°C.

#### 7.7 Address Selection

W83772G has two address pins. These pins may be either tied to Vcc, ground or left open. After the internal reset ends, W83772G pin ADD0/ADD1 will start to drive and sink current to detect the pin status – HIGH, LOW or FLOATING and then decide the SST address of W83772G. The address will be retained as long as the VCC of W83772G is maintained. The recommended pull-up or pull-down resistor value is 330Ω. (Please refer to the DC specification for the source and sink current.) The pull-up power plane must be the same as the VCC power of W83772G.

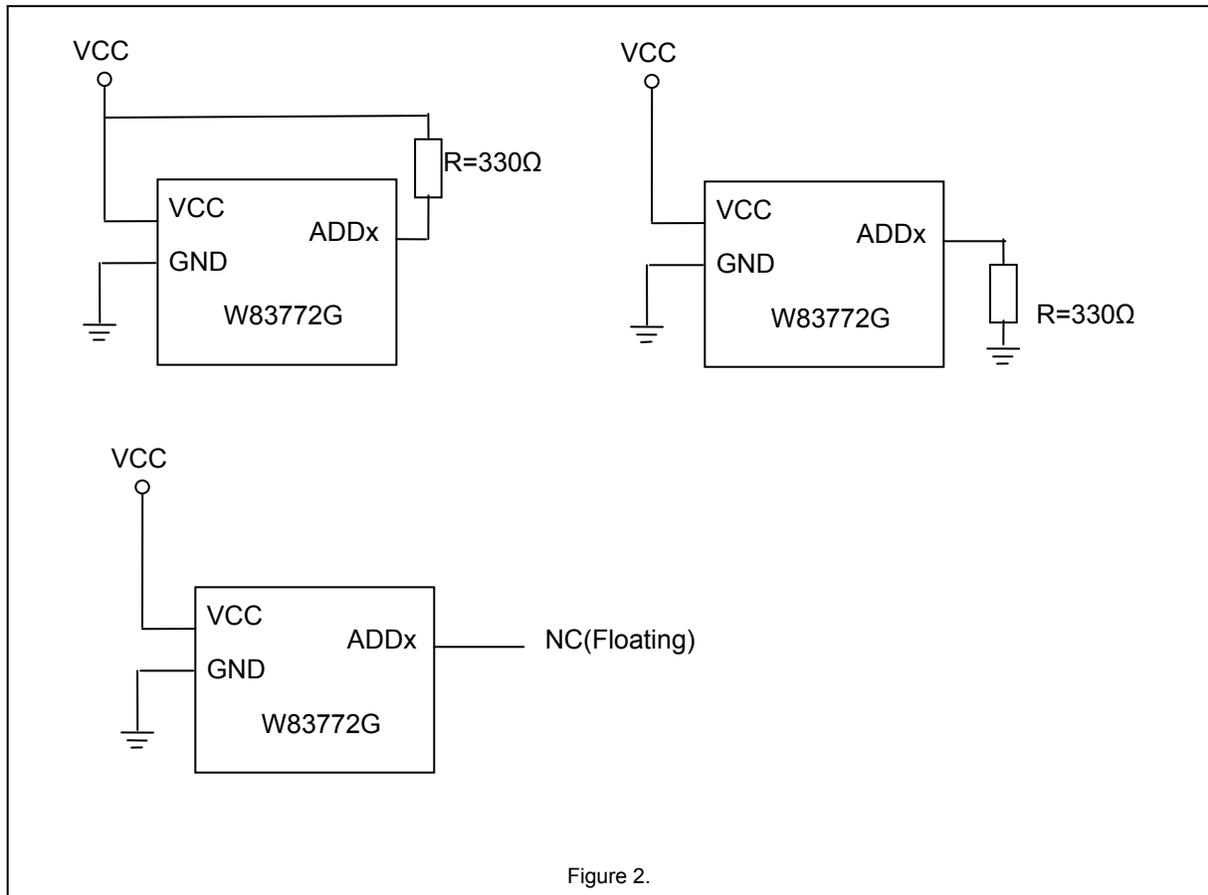

Figure 2.

The address mapping is shown in the following table.

ADD0	ADD1	ADDRESS
Ground	Ground	0x48
Open	Ground	0x49
Vcc	Ground	0x4a
Ground	open	0x4b
Open	open	0x4c
Vcc	open	0x4d
Ground	Vcc	0x4e
Open	Vcc	0x4f
Vcc	Vcc	0x50



## 8. PCB LAYOUT GUIDE

Pin 3 & Pin 4 are typically connected to a thermal diode. Here are some recommendations for optimal operation:

- a) Place remote diode as close as possible to W83772G.
- b) Route D+ and D- lines away from clock generators, memory buses, or any high frequency buses.
- c) Place shield traces, which are connecting to board ground, flanking D+/D- to shield the noise.
- d) It is recommended that the bypass capacitor with 2200pF should be placed close to W83772G to filter the noise from motherboard digital signals.
- e) Place a 0.1uF bypass capacitor close to the VCC pin.

The connection diagram is shown as the following.

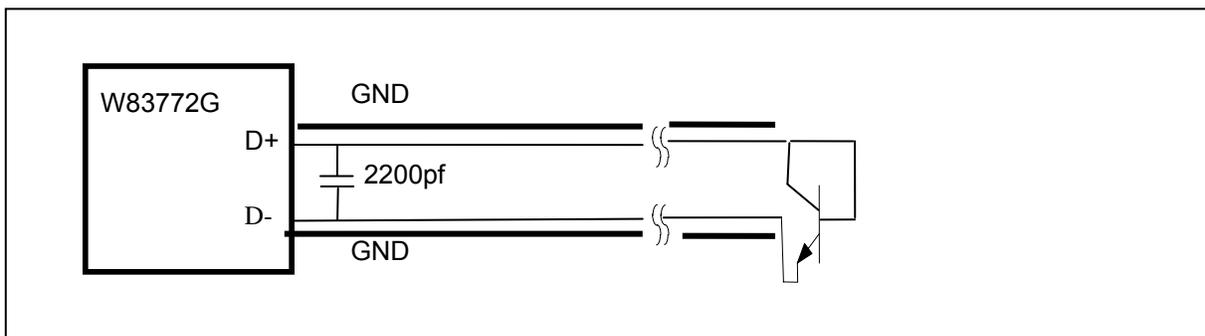

Figure 3.



## 9. COMMAND SUMMARY

The following table shows the supported SST commands. Contact Winbond for details of the commands. NDA may be required to furnish the information.

<b>COMMAND</b>	<b>DESCRIPTION</b>
Ping()	Returns a non-zero FCS over the header
ResetDevice()	W83772G will perform a functional reset similar to power-on reset
GetIntTemp()	Returns the temperature of W83772G internal thermal sensor
GetExtTemp()	Returns the temperature of W83772G external thermal diode
GetAllTemps()	Returns a 4-byte block of data (internal plus external temperatures)



## 10. ELECTRICAL CHARACTERISTIC

### 10.1 Absolute Maximum Ratings

PARAMETER	RATING	UNIT
Power Supply Voltage	3.63	V
Operating Temperature	70	° C
Storage Temperature	-30 to +127.875	° C

**Note:** Exposure to conditions beyond those listed under Absolute Maximum Ratings may adversely affect the life and reliability of the device.

### 10.2 DC Characteristics

( $T_a = 0^\circ \text{C}$  to  $70^\circ \text{C}$ ,  $V_{cc} = 3.3\text{V} \pm 10\%$ ,  $\text{GND} = 0\text{V}$ )

PARAMETER	SYM.	MIN.	TYP.	MAX.	UNIT	CONDITIONS
<b>SST</b> - This set of DC electrical specifications is used with devices normally operating from a +1.5V interface supply voltage. The following voltage and current requirements refer to the SST electrical model. For the purpose of bus capacitance, the electrical model is a two-node circuit. One node is counted for each client and one node for the system host. $V_{\text{SSTIO}}$ is the internally generated +1.5V supply voltage for the SST interface.						
IO pad power supply	$V_{\text{SSTIO}}$	1.40	1.50	1.60		
Input Voltage range	$V_{\text{in}}$			$V_{\text{SSTIO}} + 0.3$		
Input Low Threshold Voltage	$V_{t-}$	0.40		0.65	V	$V_{\text{SSTIO}} = 1.4\text{V}$ (MIN) $V_{\text{SSTIO}} = 1.6\text{V}$ (MAX)
Input High Threshold Voltage	$V_{t+}$	0.8		1.10	V	$V_{\text{SSTIO}} = 1.4\text{V}$ (MIN) $V_{\text{SSTIO}} = 1.6\text{V}$ (MAX)
Hysteresis	$V_{\text{TH}}$	0.15			V	
Output source current	$I_{\text{source}}$	-6.0			mA	$V_{\text{oh}} = 1.1\text{V}$ , $V_{\text{SSTIO}} = 1.4\text{V}$
Input High Leakage	$I_{\text{LIH}}$			+10	$\mu\text{A}$	$V_{\text{SST}} = V_{\text{SSTIO}}$
Input Low Leakage	$I_{\text{LIL}}$			-10	$\mu\text{A}$	$V_{\text{SST}} = 0\text{V}$



DC Characteristics, continued

PARAMETER	SYM.	MIN.	TYP.	MAX.	UNIT	CONDITIONS
<b>ADDx</b>						
Power Supply Voltage	V <sub>cc</sub>	2.97	3.30	3.63	V	
Input Voltage range	V <sub>in</sub>	-0.3		V <sub>cc</sub> +0.3	V	
Input High Voltage	V <sub>th</sub>	1.95			V	
Input Low Voltage				1.35	V	
Output source current	I <sub>source</sub>	-0.7		-3	mA	V <sub>oh</sub> =2.4V, V <sub>cc</sub> =2.97V
Output sink current	I <sub>sink</sub>	0.7		2	mA	V <sub>ol</sub> =0.4V, V <sub>cc</sub> =2.97V
<b>D+</b>						
Output Current I1	I1		15		uA	V <sub>cc</sub> = 3.3 V
Output Current I2	I2		165		uA	V <sub>cc</sub> = 3.3 V

### 10.3 AC Characteristics

Refer to the specification of Simple Serial Transport (SST).

W83772G



### 11. ORDER INSTRUCTION

PART NO.	PACKAGE	REMARKS
W83772G	TSSOP8	Pb-free Package

### 12. TOP MARKING

The top marking of W83772G

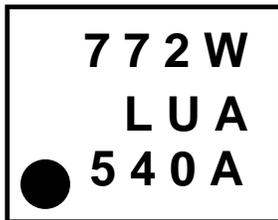

1st line: type number: 772G

2nd line: assembly house ID + internal code L UA

L: Lingsen

3rd line: Tracking code 540 G

540: packages made in '05, week 40

A: IC revision



13. PACKAGE SPECIFICATION

TSSOP 8L 3mm X 3mm

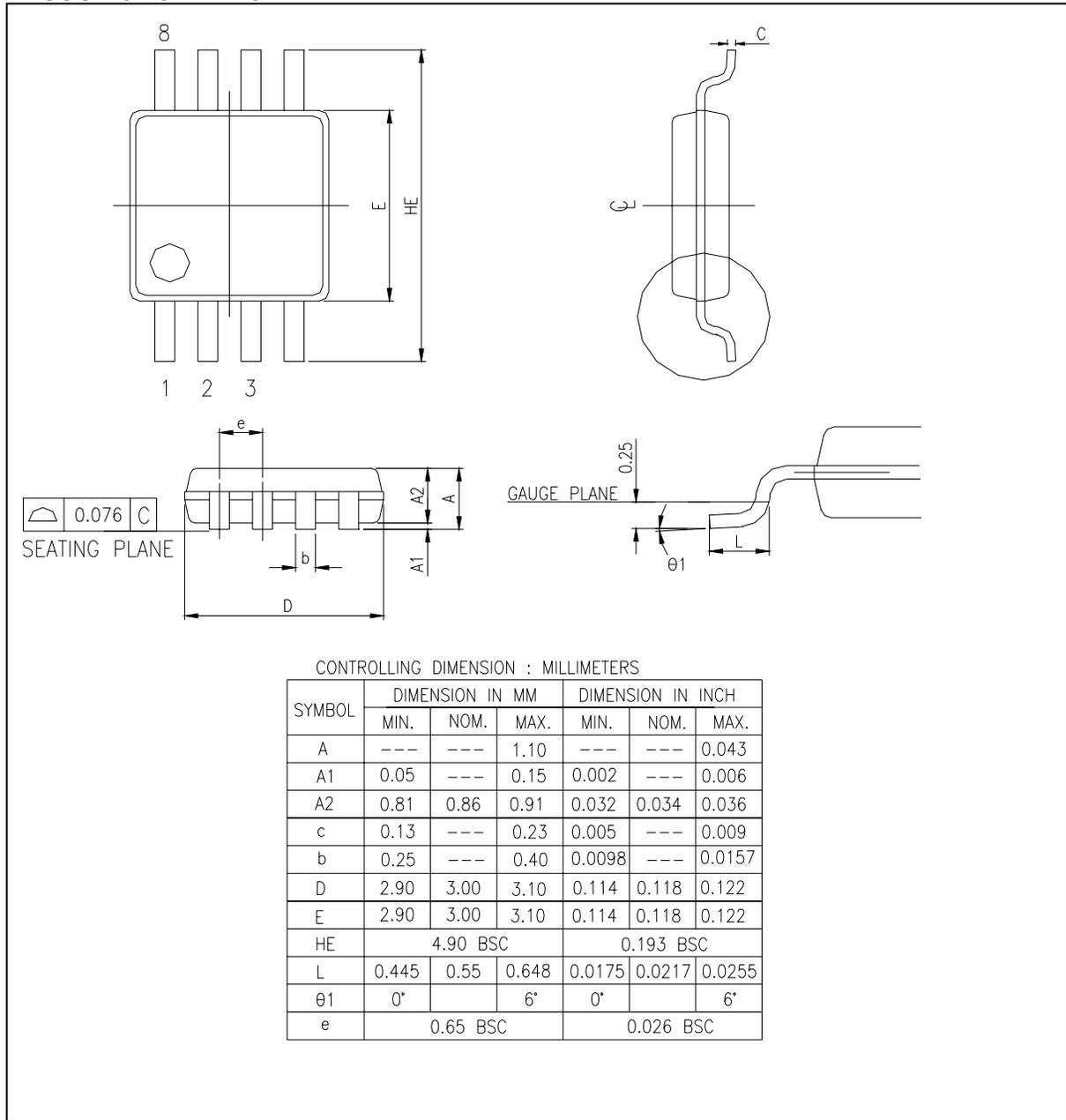

CONTROLLING DIMENSION : MILLIMETERS

SYMBOL	DIMENSION IN MM			DIMENSION IN INCH		
	MIN.	NOM.	MAX.	MIN.	NOM.	MAX.
A	---	---	1.10	---	---	0.043
A1	0.05	---	0.15	0.002	---	0.006
A2	0.81	0.86	0.91	0.032	0.034	0.036
c	0.13	---	0.23	0.005	---	0.009
b	0.25	---	0.40	0.0098	---	0.0157
D	2.90	3.00	3.10	0.114	0.118	0.122
E	2.90	3.00	3.10	0.114	0.118	0.122
HE	4.90 BSC			0.193 BSC		
L	0.445	0.55	0.648	0.0175	0.0217	0.0255
theta1	0°	6°		0°	6°	
e	0.65 BSC			0.026 BSC		



### Important Notice

Winbond products are not designed, intended, authorized or warranted for use as components in systems or equipment intended for surgical implantation, atomic energy control instruments, airplane or spaceship instruments, transportation instruments, traffic signal instruments, combustion control instruments, or for other applications intended to support or sustain life. Further more, Winbond products are not intended for applications wherein failure of Winbond products could result or lead to a situation wherein personal injury, death or severe property or environmental damage could occur.

Winbond customers using or selling these products for use in such applications do so at their own risk and agree to fully indemnify Winbond for any damages resulting from such improper use or sales.

---

*Please note that all data and specifications are subject to change without notice.  
All the trademarks of products and companies mentioned in this datasheet belong to their respective owners.*